

COVERED PRODUCTS

KERNOW CLADDING cladding KERNOW CLADDING decking boards

In order to maintain the excellent appearance of KERNOW CLADDING products for many years the following steps must be carried out properly:



These Installation instructions cover the steps from 1 to 4. You can find maintenance recommendations for KERNOW CLADDING products in the Product Specification.

Installation instructions provide general reference for KERNOW CLADDING cladding and KERNOW CLADDING decking boards installation, the drawings show general principles and are not universally applicable to every project. Cladding and decking boards installation solutions for a certain project should be designed taking into account the particularity of the project and in accordance with the applicable building regulations and standards.

If the instructions of storage, installation and maintenance of KERNOW CLADDING cladding and / or KERNOW CLADDING decking boards are not followed, we do not accept any claims regarding the quality of the product over time.

STORAGE ON THE CONSTRUCTION SITE

Proper storage significantly reduces the potential for charred wood products deformation, cracking, and discoloration. The following conditions must be ensured for proper storage of KERNOW CLADDING cladding or terrace boards:

- The boards must be stored in a stack placed on a level surface.
- To ensure adequate air circulation between the surface and the bottom row of the boards, the stack must be lifted minimum 100 mm above concrete flooring and 300 mm above unpaved ground. Blocks, beams or brick pillars could be used for this purpose.
- It is also important to ensure sufficient air circulation between the rows of the stack. This can be done by laying transverse battens with a thickness of at least 15 mm. The battens must be of the same thickness and placed in each row of the stack. They must be placed at least 100 cm apart at the same location at each row of the stack so that the weight of the boards would be transferred directly down the stack to the supports.
- Weights (e.g. blocks) should be placed on top of the stack to prevent the top row of the boards from moving.
- It is recommended to store the boards of different length and material separately. If it is not possible, longer boards must be placed in the bottom layer and shorter boards in the top layer, but one end of the stack should be kept in true vertical alignment.
- The boards must be stored in such a way as to be protected from impact and scratches.
- The boards must be stored in a place insulated from direct sunlight.
- The stack must be protected from precipitation (e.g. with a roofing or a PVC film), but in such a way as to ensure air circulation, i.e. without sealing it completely.
- Recommended width and height of the stack are up to 1,5-2 m.

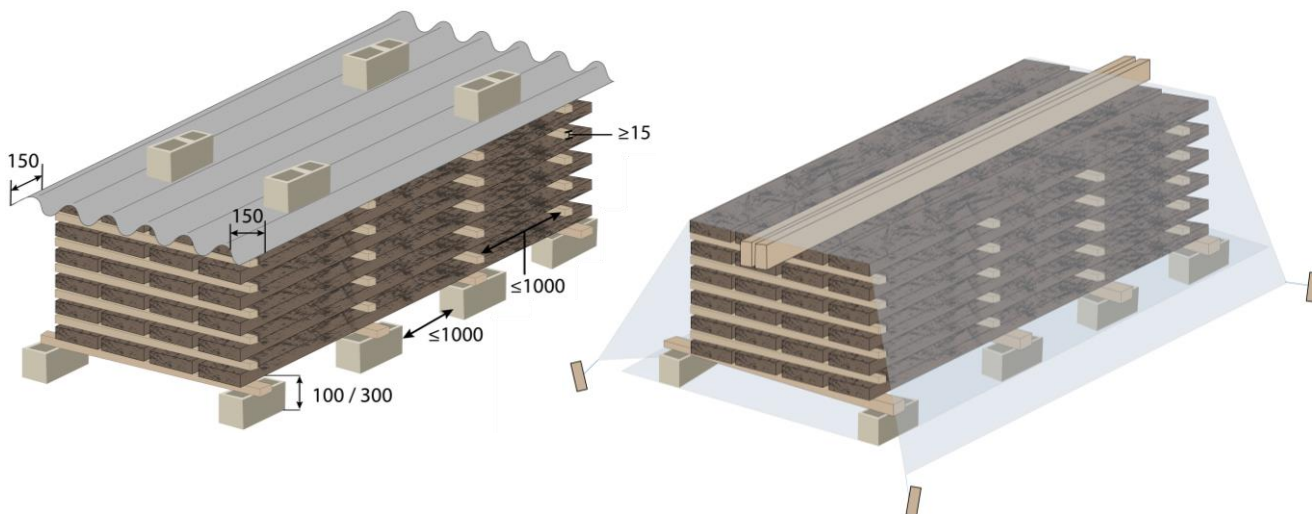
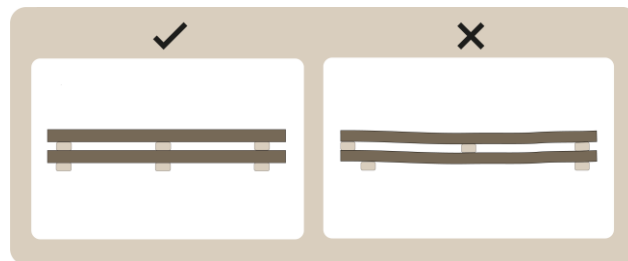

A stack of boards covered with roofing

A stack of boards covered with PVC film

NOTES: pictures are not to scale; all dimensions in millimetres (mm)

ACCLIMATION

Proper acclimation is a very important step to ensure high quality of installation of wood products. Acclimation is key to minimizing wood movement. It is assumed that the thickness and width of a wood product changes by 1 % every 4 % change of wood moisture content. KERNOW CLADDING cladding or terrace boards must be acclimated in the environment where they will be installed for at least 72 hours prior to installation and must also be protected from moisture with good air circulation. Improper acclimation can cause cupping, buckling, warping or shrinking and also can result in damage of the boards as they move against the fasteners.

CLADDING INSTALLATION

Frame and substrate

Frame should be constructed by wooden battens of 22 - 25 mm thickness and 50 mm width. Spacing between the battens should be placed 500 mm apart.

Reaction to fire class of the battens must be D-s2, d0 or better. Substrate should be A1 class or A2-s1,d0 class with a minimum density of 525 kg/m³. These parameters should be met to ensure the declared cladding reaction to fire classification. Additional installation conditions may be specified in the declaration of performance for the specific product.

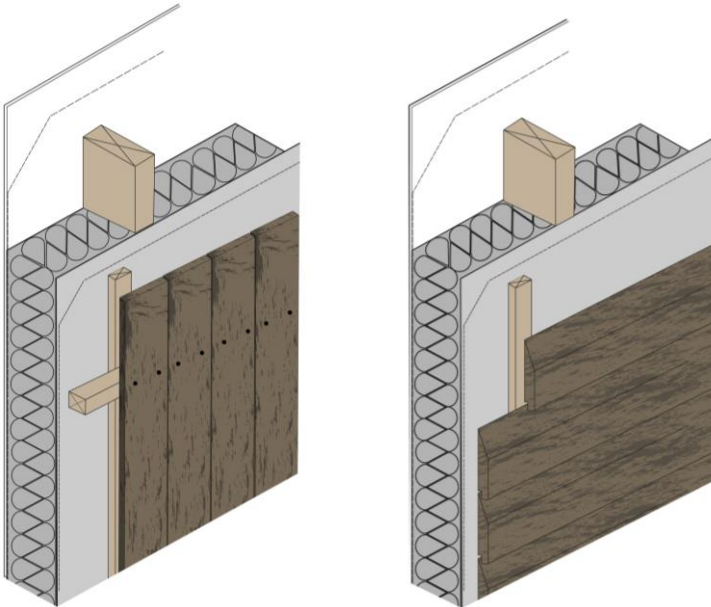

In case of vertical cladding, a double frame is constructed. Horizontal battens are fastened on vertical battens. The top side of the horizontal battens should be chamfered at an angle of 15 degrees to shed water into the ventilated cavity. Cut the top and bottom of the board so that the raindrops can roll down (cut at an angle of at least 15 degrees). Carefully coat the cuts with WOCA Exterior Wood Oil or fire retardant Ultra.

In case of horizontal cladding, boards are fastened on vertical battens.

It is recommended to avoid board joints. If joints are necessary, try to join boards in such a way that water does not enter the joint: join as firmly as possible, carefully coating the cuts with WOCA Exterior Wood Oil or fire retardant Ultra. Board joints must occur at battens.

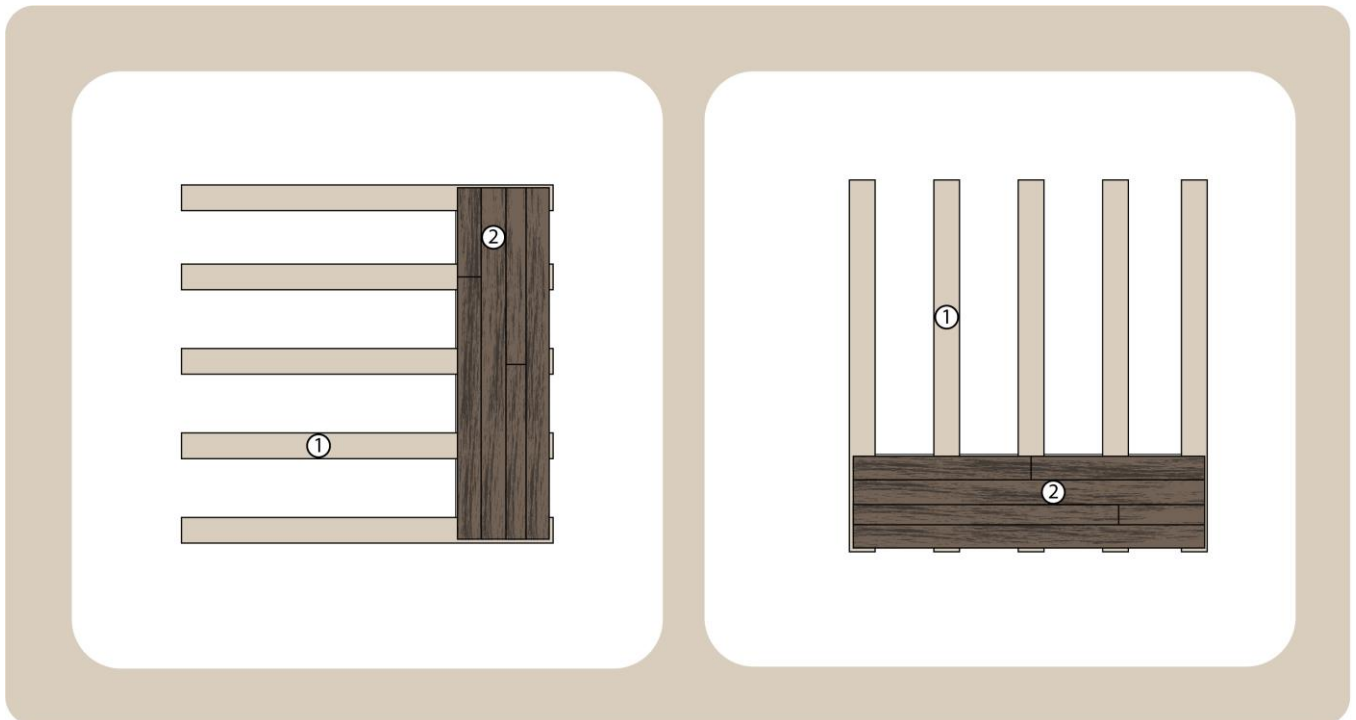

1 – frame batten

2 – KERNOW CLADDING cladding

NOTE: pictures are not to scale

A gap of at least 15 mm must be left between the lower part of the roof and the cladding for ventilation, through which air can move both behind the cladding and under the roof. When meeting other construction elements, a free space of at least 15 mm should be allowed for. The roof or window sill should have at least 30 mm overhang.

The height of the plinth must be such that the lower edge of the cladding is at least 300 mm above the ground. This will avoid rain water splashing on the lower part of the cladding.

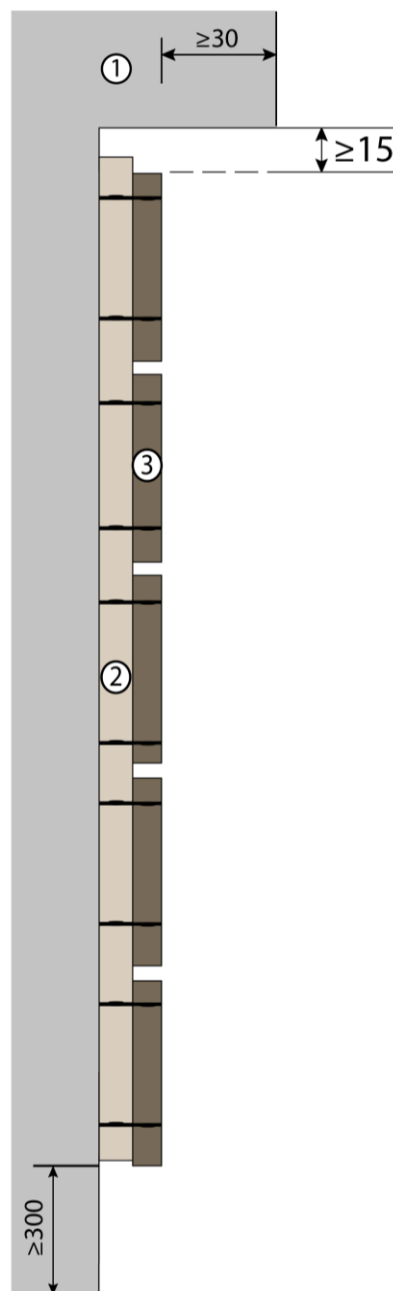
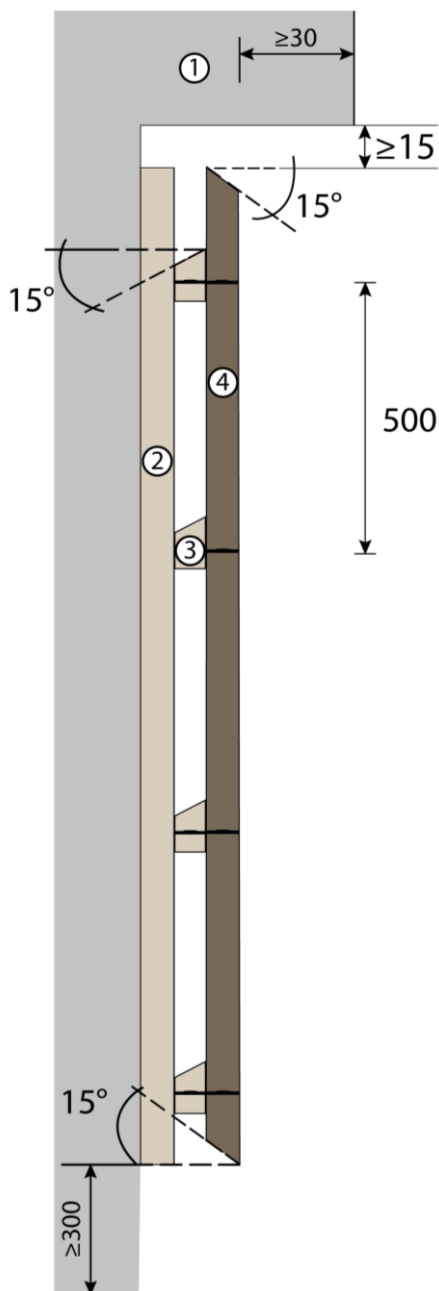

Vertical cladding installation

- 1 – building structure
- 2 – vertical frame batten
- 3 – horizontal frame batten
- 4 – KERNOW CLADDING cladding

Horizontal cladding installation

- 1 – building structure
- 2 – frame batten
- 3 – KERNOW CLADDING cladding

NOTES: pictures are not to scale; all dimensions in millimetres (mm) unless noted

Fasteners

All metal fixings should be made from corrosion resistant material. We recommend stainless steel colored heads Essve screws. The screws must be at least 50 mm long.

For boards 100mm and wider, two screws per board should be used. Screws should be positioned 25% from each side on the board and at least 70 mm from the top or bottom. For boards with thickness of 100 mm and less one centrally placed screw could be used.

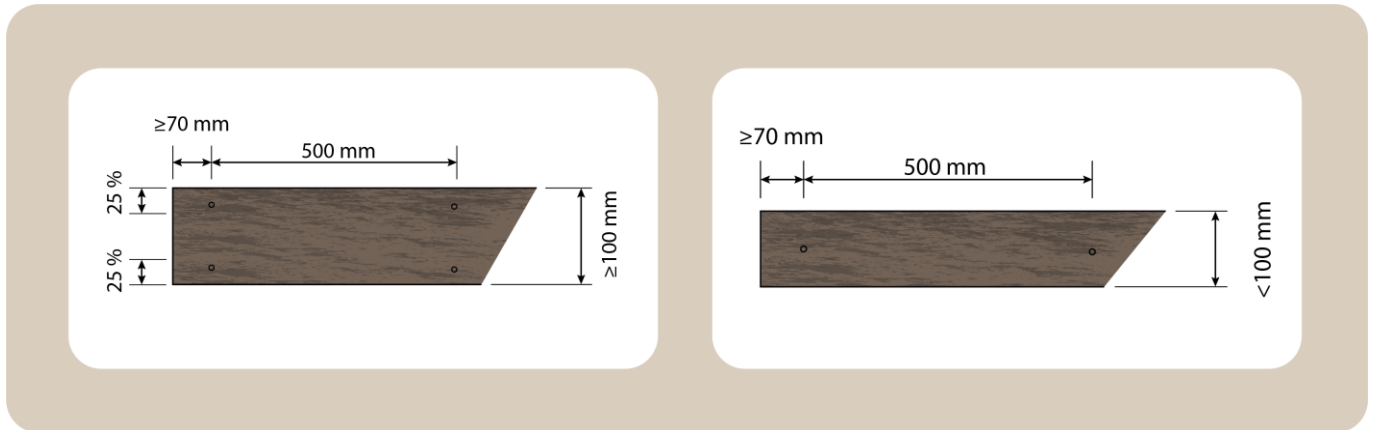

NOTE: pictures are not to scale

It is recommended to pre-drill pilot holes of 70-80 % of shank diameter at the ends of the board to prevent potential splitting. For wood species of higher density (e.g. larch) with a higher risk of splitting around fixing points pre-drilling is recommended at every fixing point (not only at the ends of the board).

The screws should finish flush with the surface of the cladding. It is important to ensure that the cladding moisture content is around 16 % at a time of installation to avoid shrinkage that would leave screws proud of the cladding surface. Pneumatic screwdrivers should be used with care to ensure the surface of the cladding is not affected by impact damage or the screws driven below the surface.

In case of the board on board style, the screw used to install the top board must never pass through the underside board. This is because any movement (expansion and contraction) of the top and bottom boards caused by seasonal moisture changes will result in splitting.

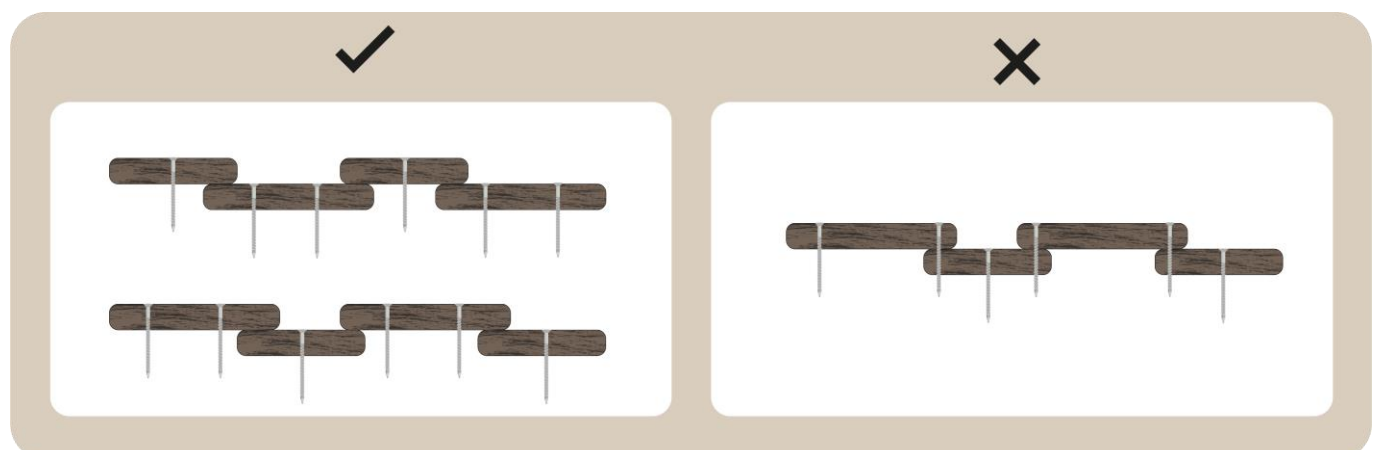

NOTE: pictures are not to scale

Positions of the screws when installing cladding vertically

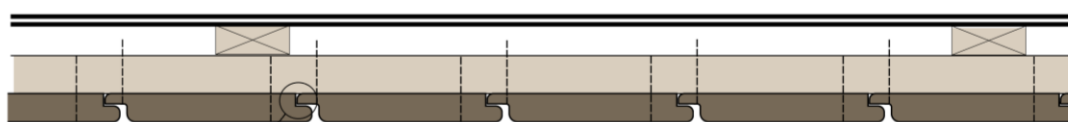

Vertical mounting shiplap

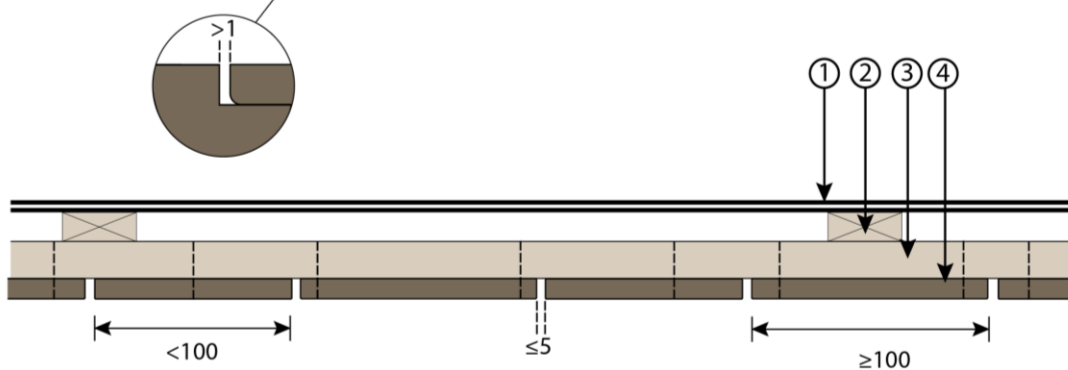

Rectangular mounted with open joints

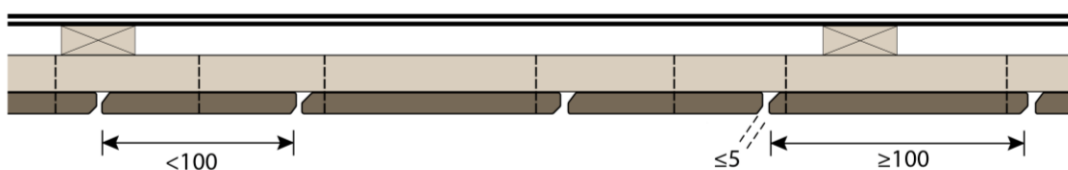

Rhombus mounted with open joints

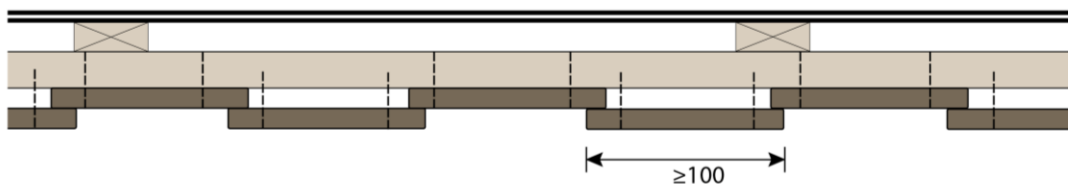

Rectangular mounted board on board style

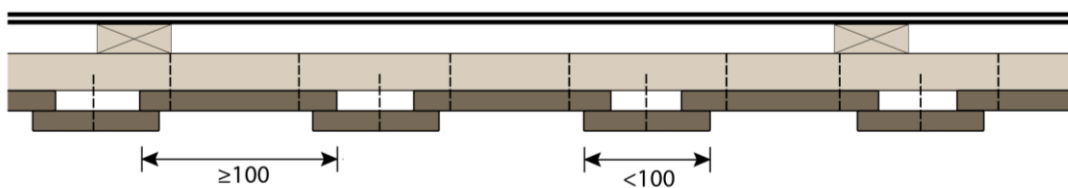

1 – substrate

2 – vertical frame batten

3 – horizontal frame batten

4 – KERNOW CLADDING cladding

NOTES: pictures are not to scale; all dimensions in millimetres (mm)

Positions of the screws when installing cladding horizontally

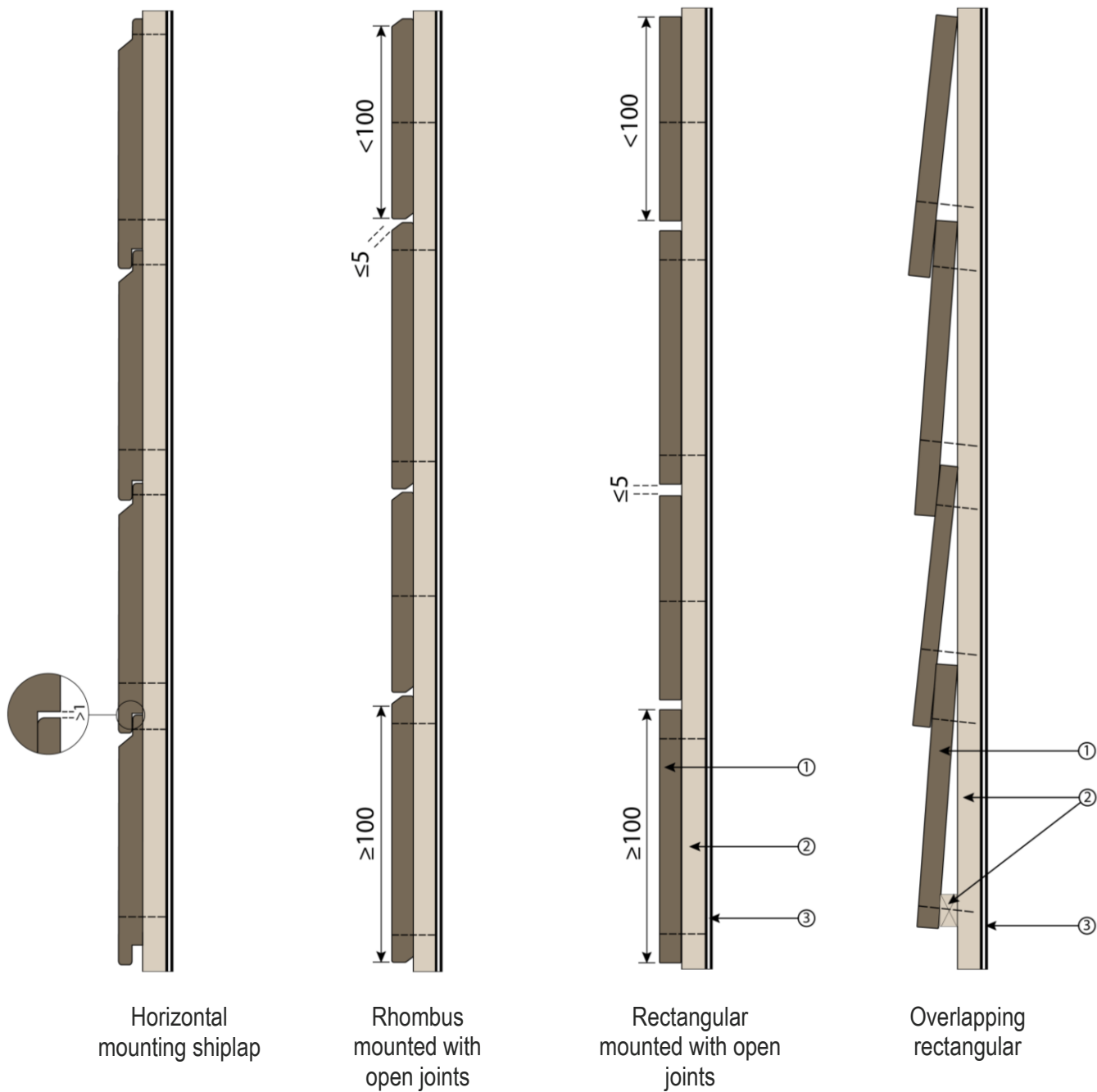

- 1 – KERNOW CLADDING cladding
- 2 – frame batten
- 3 – substrate

NOTES: pictures are not to scale; all dimensions in millimetres (mm)

DECKING INSTALLATION

Building the substructure

The recommended material for the substructure is wood of the same species or similar density to the decking boards. The common choice is double substructure of beams and joists, fixed perpendicular to the beams. The joist size should be about 50 mm x 150 mm. Spacing between the joists should be placed 400-600 mm apart.

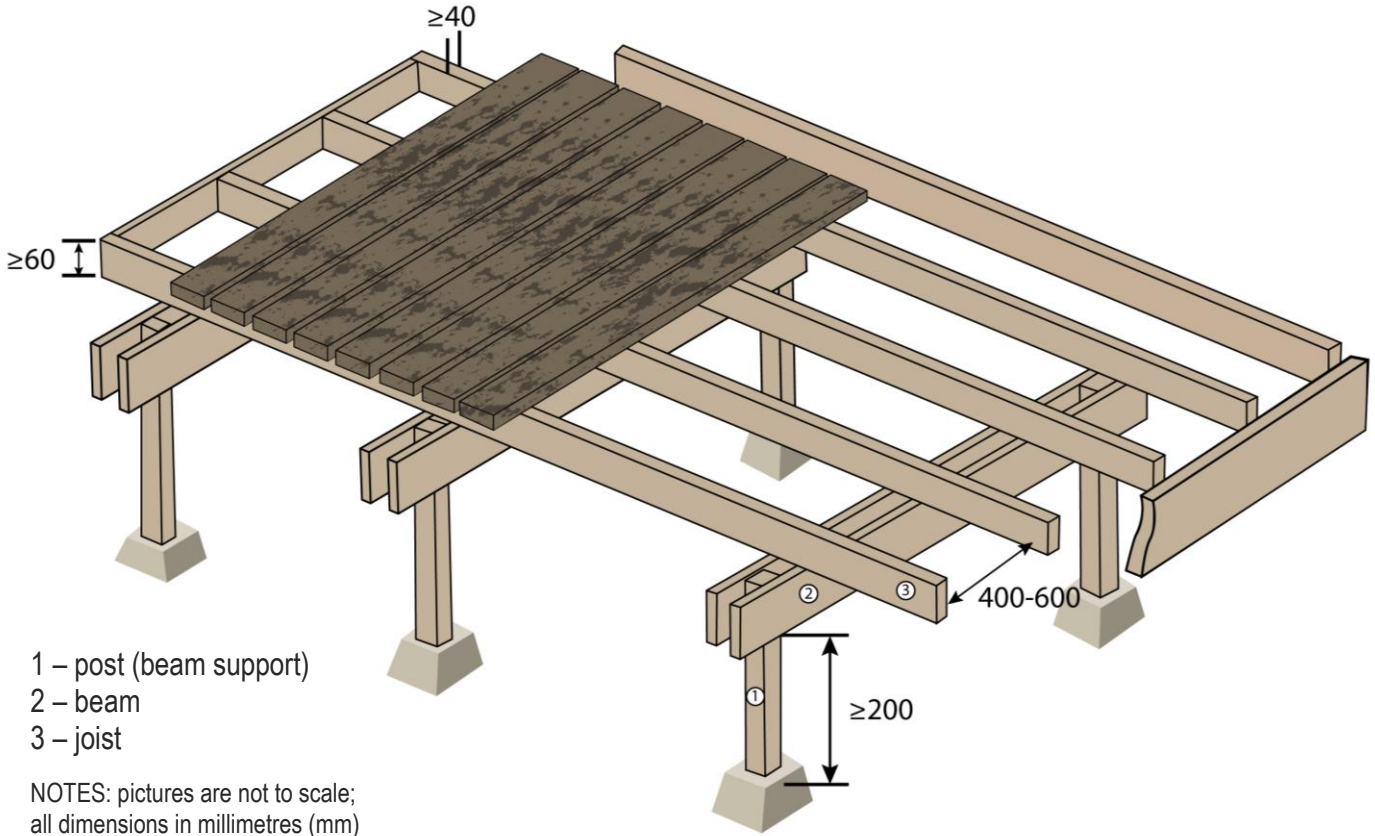

- 1 – post (beam support)
- 2 – beam
- 3 – joist

NOTES: pictures are not to scale;
all dimensions in millimetres (mm)

It is very important to prevent ponding of water under the terrace, so a drainage layer is required and the ground under the terrace should have a fall. A slight fall should also be built into the terrace surface for water run-off. If the terrace is to be adjoined to a building or other structure, then the fall should be away from the adjacent structure.

When the terrace is attached to the building, a minimum 10 mm gap must be left to ensure ventilation and rainwater drainage.

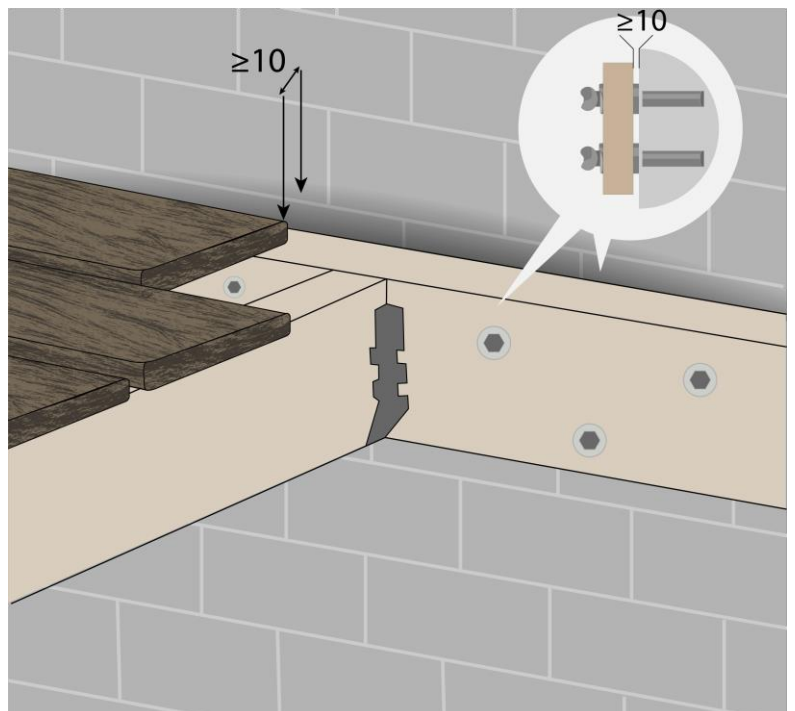

NOTES: pictures are not to scale; all dimensions in millimetres (mm)

Various orientations of KERNOW CLADDING decking boards are available. Boards may be laid vertically, horizontally, diagonally or any combination of these depending on the particular project. If the terrace installation requires the boards cutting, cuts must be carefully coated with WOCA Exterior Wood Oil.

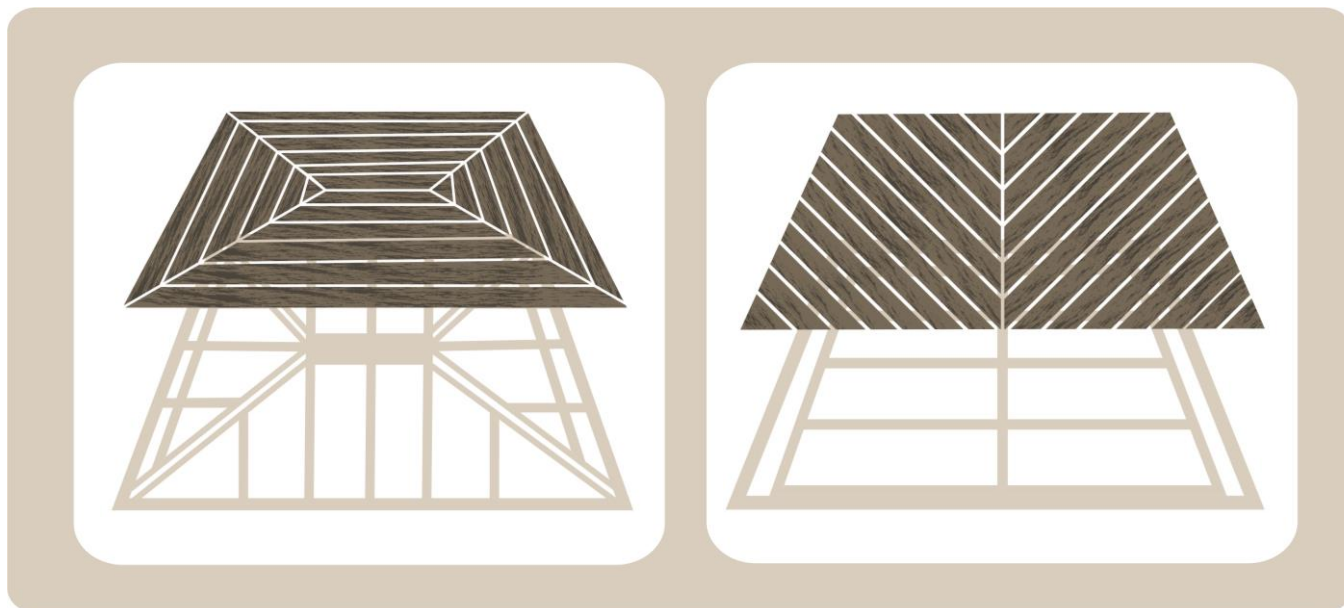

Fixing

The decking boards must be fixed with a gap of 5-8 mm between the boards to allow natural movement of wood and to ensure appropriate ventilation and drainage of the terrace.

The board must be fixed to each crossing joist with two screws positioned at least 25 mm from the ends of the board. Screws should be between 2-3 times the length of the board thickness. We recommend stainless steel Essve screws for decking boards fixing.

Standard installation

When choosing standard installation, screws are screwed into the surface of the terrace board and remain visible. Screws must be positioned at a quarter points of the board width. To avoid splitting, pre-drilling is recommended. Pneumatic screwdrivers should be used with care to ensure the surface of the board is not affected by impact damage or the screws driven below the surface. The screw heads must be level with the surface of the decking boards and no deeper, otherwise fixing points form moisture and dirt collecting dips that can cause deterioration of the wood.

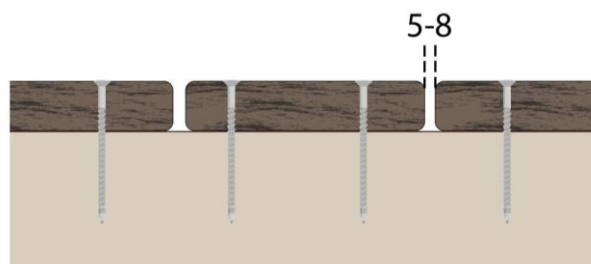

Concealed installation

When choosing concealed installation, screws are inserted diagonally (at an angle of 45 degrees) into the sides of the decking board with a specialised tool and become invisible.

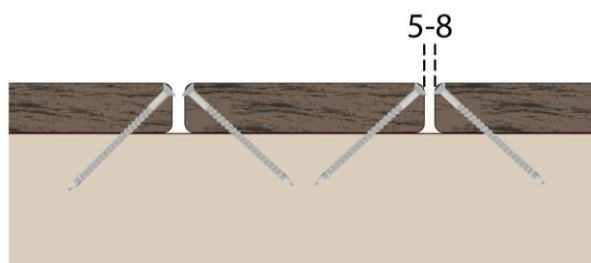

NOTES: pictures are not to scale; all dimensions in millimetres (mm)

Top tip for non-experienced DIY'ers

Do not rush to fasten decking boards to the frame. Lay all the boards loosely on the prepared frame. This prevents unpleasant surprises.

EXAMPLES

This section provides general examples of cladding installation. The design of the particular project should always be checked by a qualified engineer to ensure the strength of the system. The design of the whole system must be in accordance with all applicable regulations.

Pictures are not to scale; all dimensions in millimetres (mm).

Interior corners

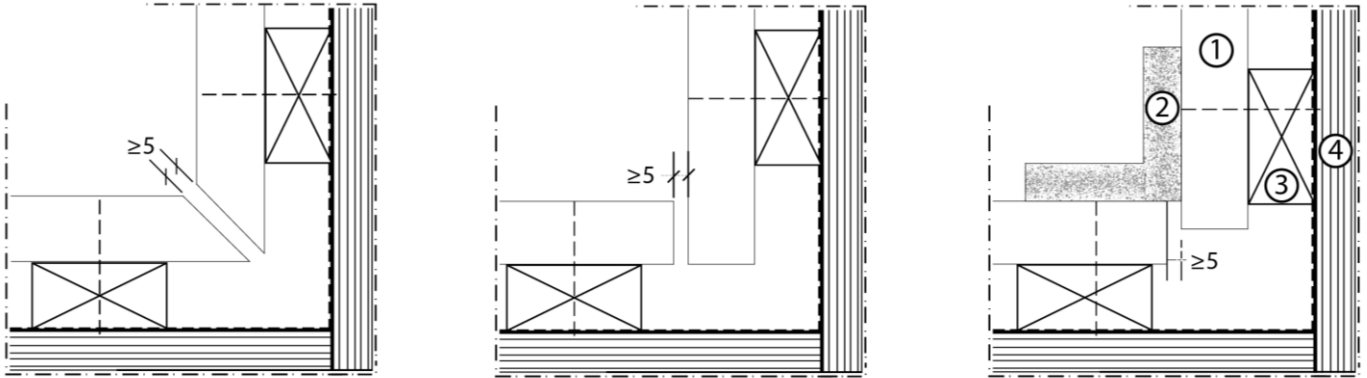

- 1 – KERNOW CLADDING cladding
- 2 – KERNOW CLADDING interior trim angle

- 3 – frame batten
- 4 – wall structure

Exterior corners

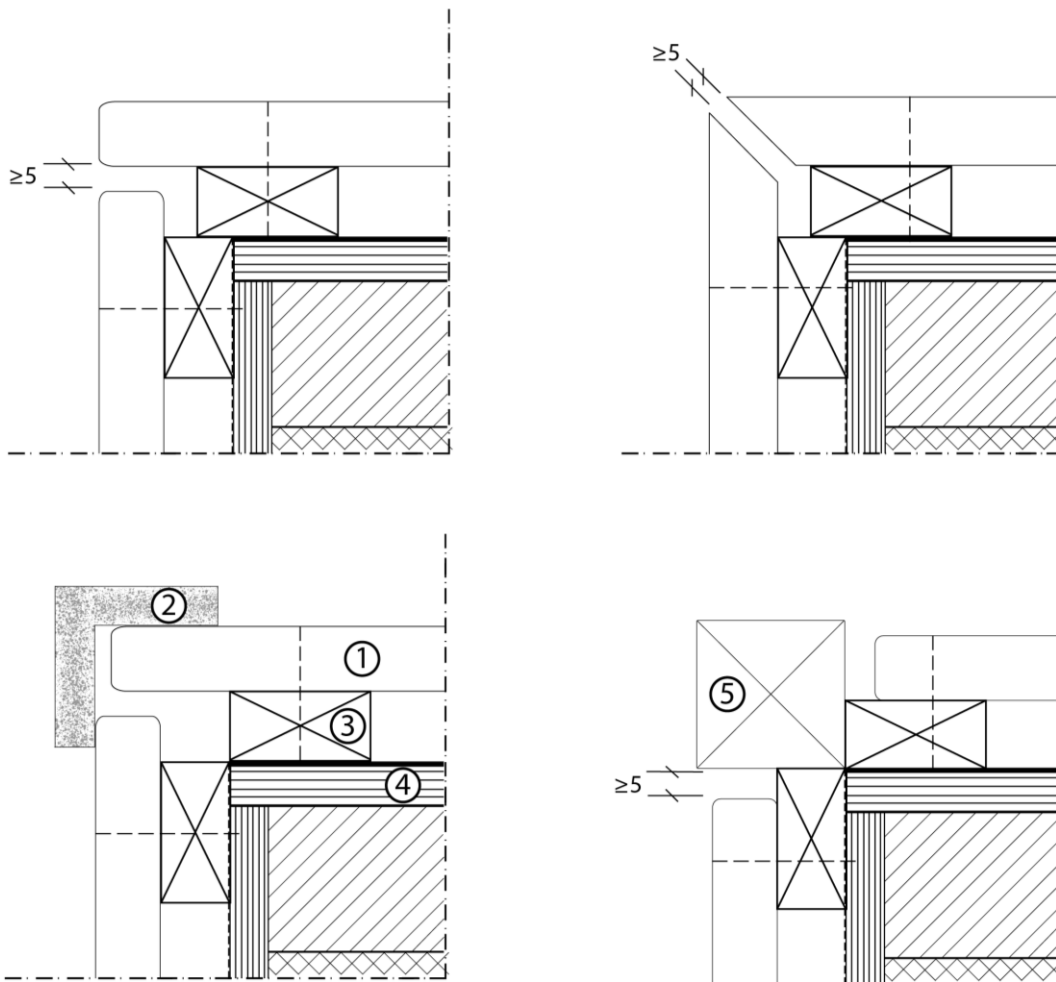

- 1 – KERNOW CLADDING cladding
- 2 – KERNOW CLADDING exterior trim angle
- 3 – frame batten

- 4 – wall structure
- 5 – KERNOW CLADDING batten

Window head

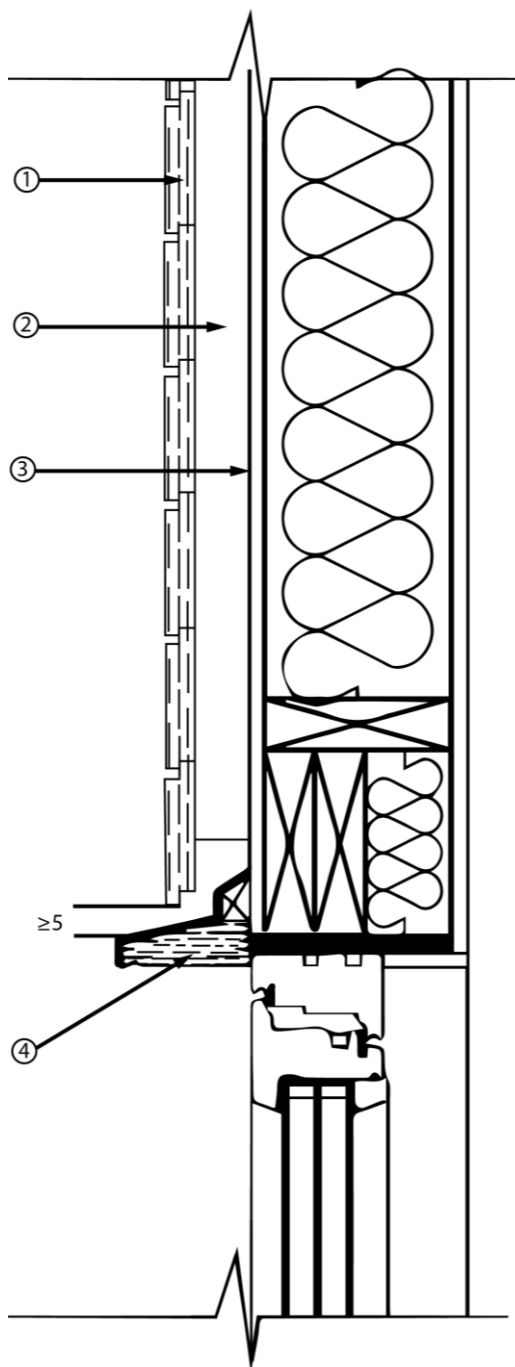

Horizontal cladding

- 1 – KERNOW CLADDING cladding
- 2 – vertical frame batten
- 3 – wall structure
- 4 – window frame

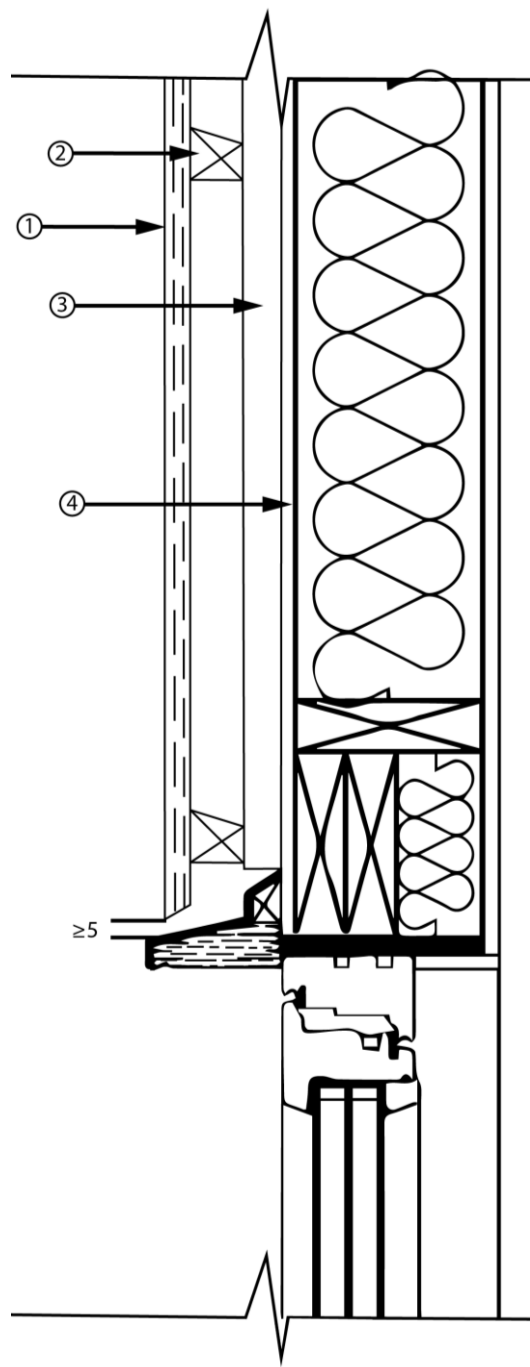

Vertical cladding

- 1 – KERNOW CLADDING cladding
- 2 – horizontal frame batten
- 3 – vertical frame batten
- 4 – wall structure

Window sill

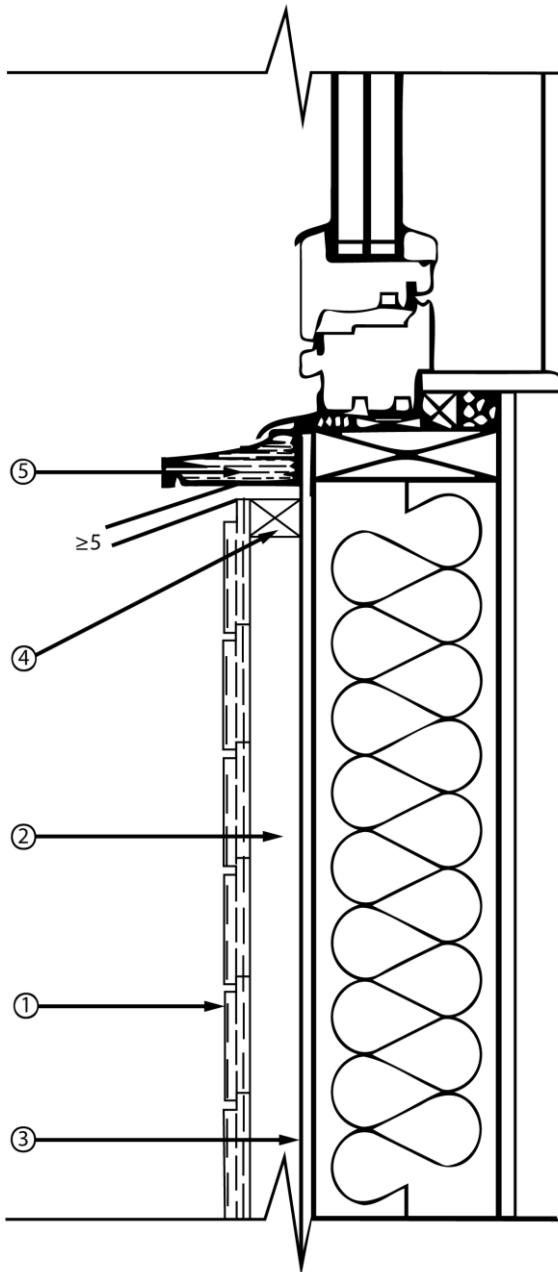

Horizontal cladding

- 1 – KERNOW CLADDING cladding
- 2 – vertical frame batten
- 3 – wall structure
- 4 – horizontal batten
- 5 – window frame

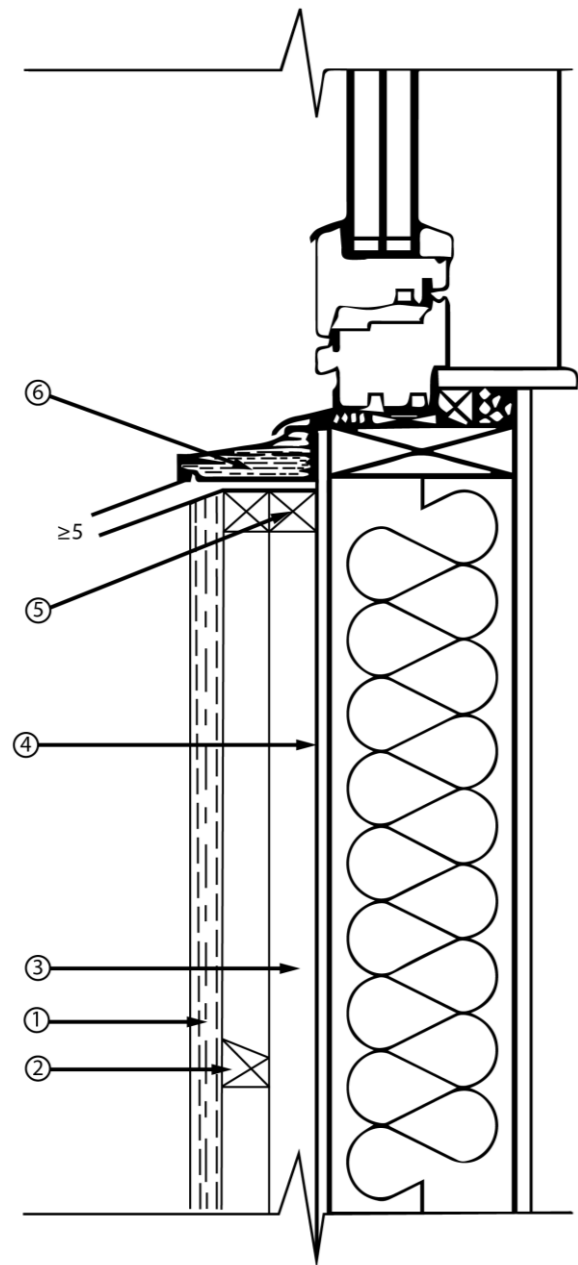

Vertical cladding

- 1 – KERNOW CLADDING cladding
- 2 – horizontal frame batten
- 3 – vertical frame batten
- 4 – wall structure
- 5 – horizontal batten
- 6 – window frame

Window jamb

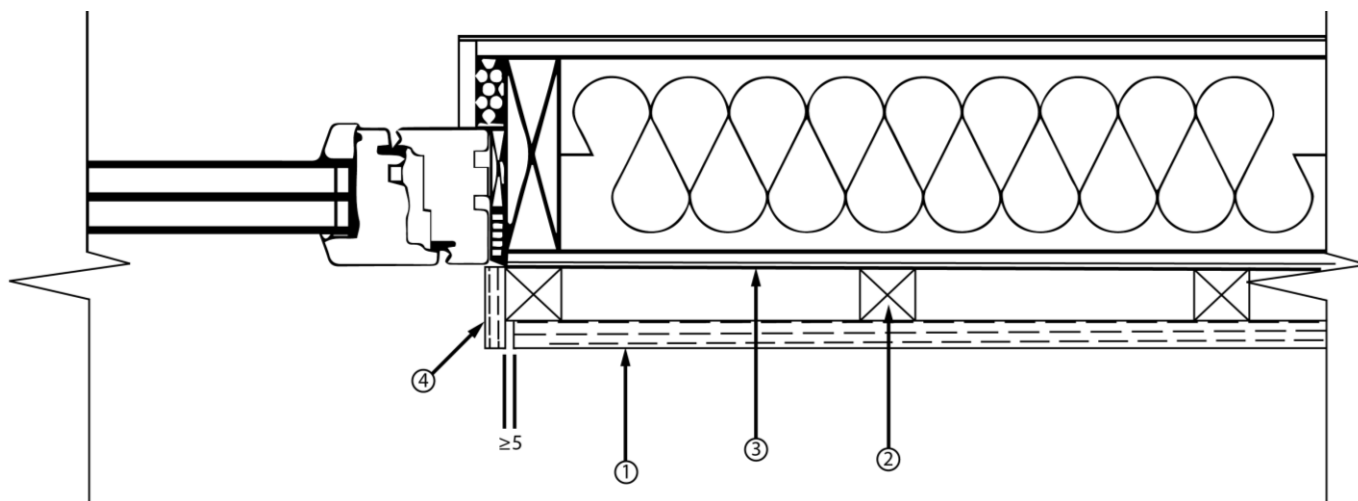

Horizontal cladding

1 – KERNOW CLADDING cladding
2 – vertical frame batten

3 – wall structure
4 – KERNOW CLADDING finishing strip

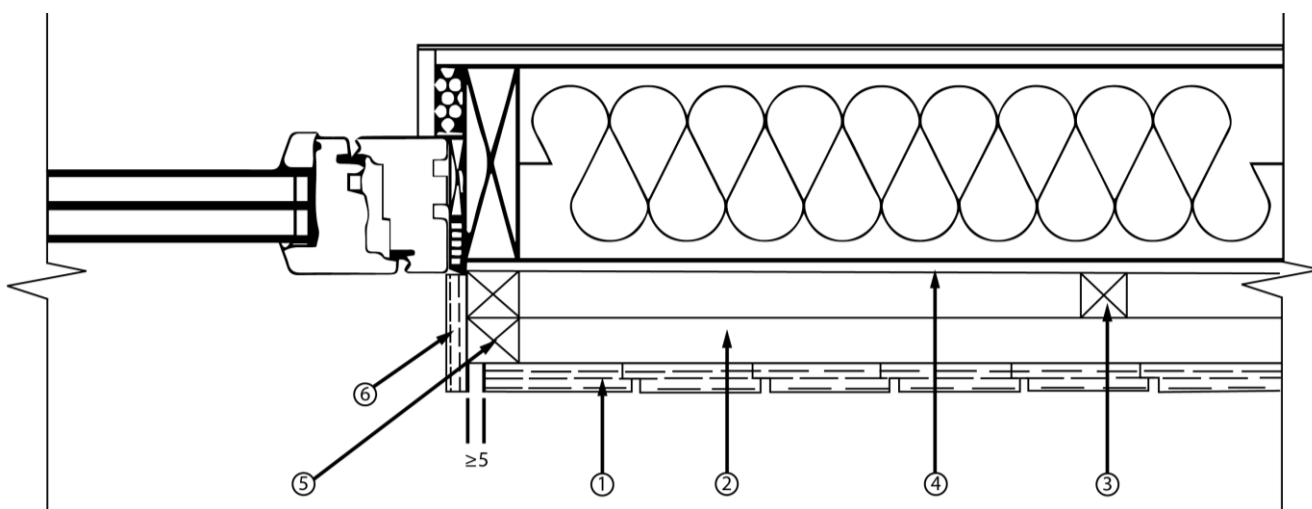

Vertical cladding

1 – KERNOW CLADDING cladding
2 – horizontal frame batten
3 – vertical frame batten

4 – wall structure
5 – vertical batten
6 – KERNOW CLADDING finishing strip



kernow

C L A D D I N G

www.kernowcladding.co.uk

E: info@kernowcladding.co.uk

T: 0330 1220810